

PILATUS PC-7 SMOKE GENERATION SYSTEM



Description

Swiss Helicopter Engineering has developed in cooperation with AeLo Maintenance (www.aelo.ch) the certified installation of a 5.5 gallons smoke generation system of Smoking Airplanes (www.smokingairplanes.com) to be installed in the aircraft battery compartment. The smoke generation system is designed to provide more than 7 minutes of runtime and it is rated for 18g accelerations. The smoking generation is activated from a switch installed in the aircraft cockpit to be easily used by the pilot during aerobatic manoeuvres.



Modification details

- ✓ Rated for 18g aerobatic manoeuvres
- ✓ Total runtime >7 minutes, 5.5 US gal capacity
- ✓ No airspeed limitation
- ✓ No sacrifice of space in baggage compartment
- ✓ Engineered from customer experience

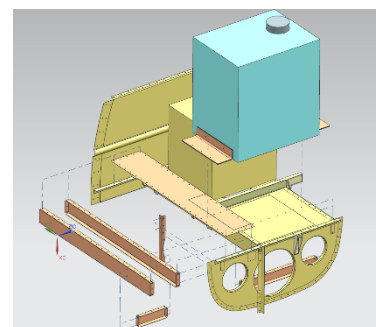

Approvals

Approval type	Reference number	Authority	Aircraft approved
Minor Change	2020-00003	Swiss FOCA	Pilatus PC-7

Approval can be validated to other civil aviation authority and extended to other aircraft on request.

INTERESTED?
CONTACT US FOR A QUOTATION
>>> engineering@she-ag.ch

swiss
helicopter 
engineering

Via Aeroporto 17 – 6596 Gordola (Switzerland)
EASA DOA - EASA.21J.730